

FORM 130 & FORM 140 Installation Guide



Measurements.

PROFILE.	SOLID (mm)	Finish.
FORM 130	130 x 19 x 4850	Solid - Smooth & Grooved
FORM 140	140 x 25 x 4850	Solid - Smooth & Grooved

Specifications.

SPECIFICATION.	FORM 130	FORM 140
Substructure	Timber / Aluminum	Timber / Aluminum
Board Coverage	135 mm	145 mm
Maximum Joist Spacings	400 mm	450 mm
Maximum Board Overhang	10 mm	20 mm
Minimum Ground Clearance	As per the NZ Building Code.	
Minimum Ground Clearance Over Membrane	As per the NZ Building Code.	
Minimum Gap between Each Board	5 mm	5 mm
Minimum Screw Distance from Board Edge	30 mm	30 mm
Expansion Gap	0-4 mm	0 - 4 mm
Hidden Clip & Screw	Every Joist	Every Joist
Torx Deck Screw 304 or 316 Stainless Steel	60 mm	60 mm
Perimeter & Breaker Board	Surface Fix	Surface Fix
Windy Exposure (Wind Break Use)	Windbreak Plus	Windbreak Plus

- Lengths are 4850mm however up to 5mm variation can occur. Please dock to uniform length on site.
- For timber joists, we recommend uniform height and thickness SG8 joists.

It is the responsibility of the installer to comply with all local regulatory body rules.

Safety Equipment.

Be safe. Always use appropriate safety equipment. We highly recommend using the following:

- Safety Glasses
- Safety Gloves
- Dust Mask
- Ear Muffs/Plugs
- Safety Shoes/Boots
- Long Sleeves

It is the responsibility of the purchaser, contractor, builder or installer to comply with normal safety practice standards in regards to any application or use of any BiForm Decking products.

Tool List.

Ensure that you have the correct tools before you start, this will make installing your BiForm deck an enjoyable experience.

- Square
- Tape Measure
- Spirit Level
- Rubber Hammer/Mallet
- Cordless/Electric Drill
- Circular Saw/Drop Saw - recommend 80 teeth blade.
- #1 Square Drive Head Bit - min 50mm
- #2 Square Drive Head Bit
- Builders Pencil

Note.

Please ensure you read all subsequent pages for important instructions on storage, handling, care etc.



FORM 130 & FORM 140 Installation Guide

Storage and Handling.

- Boards should be transported flat (eg. not angled on the back of a ute).
- Carry the boards vertically, as shown below.
- Store the boards on a dry, level surface preferably sheltered area.
- Lay the boards flat (as per picture below), and not at an angle.
- Keep the boards off the ground using gluts underneath.
- Gluts to be used to support decking every 500mm.
- Be careful when stacking boards - do not drop, dump or throw.
- Cover the boards until required for installation.

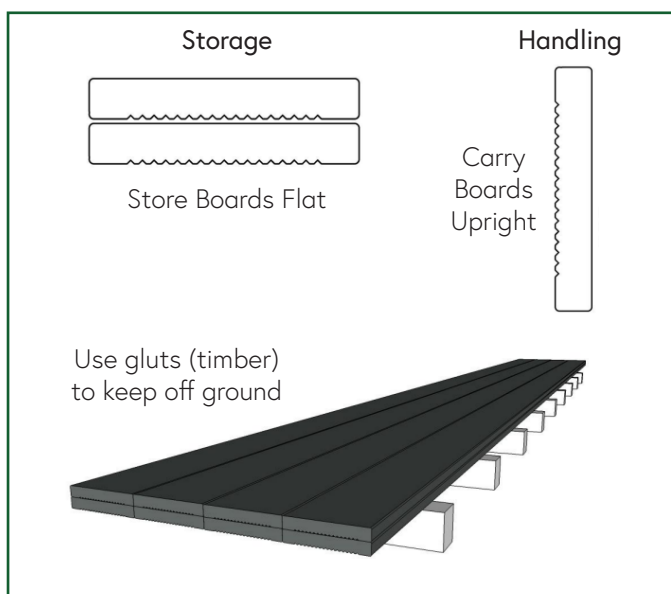

Cornering Options.

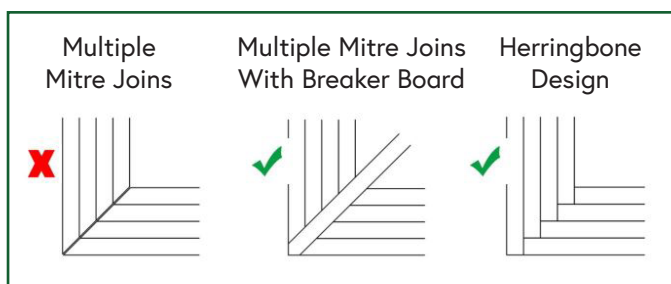

- See our CAD Drawings online at <https://biform.co.nz/resources-cad-drawings> for a more detailed view of our recommended cornering options.
- While these diagrams accurately depict how best to use our composite decking, we would still strongly suggest consulting with our friendly staff who are more than happy to assist you with your decking layout.

Layout Options.

Breaker Boards:

Composite decking can expand and contract with a rise and fall in temperature. Depending on the environment, there can be up to 5mm per full length board (approximately 1mm per metre).

Due to this thermal movement, composite decking should be installed with the use of a picture frame and/or breaker boards.

A breaker board is a board that runs perpendicular to the main run of decking and helps to minimise thermal movement.

*Butt joints are NOT appropriate with FORM decking due to the expansion and contraction.

See diagrams below for layout examples:

Picture Frame and Breaker Board

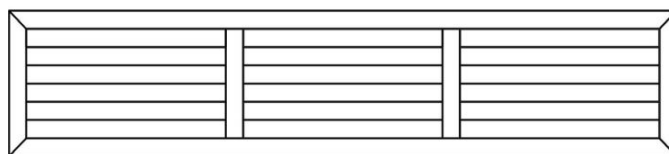

While mitred corners are a popular option, due to the expansion and contraction, they work best when lengths are 2.4m or less, surface fixed and installed while cool and contracted.

Breaker Board Only

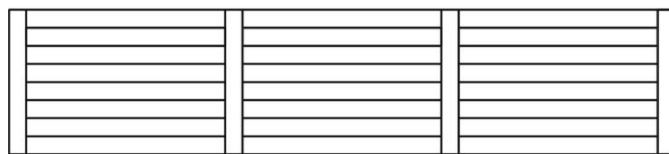

Breaker boards can be placed where ever you feel suits your outdoor area.

While some customers will prefer the symmetry of the designs above, others can choose where to position their breaker boards, lining them up with doorways, windows, or steps.

Factoring in wastage, getting the most out of our 4850mm boards, is also a very important consideration.

If we haven't already, we can draw up a recommended layout for your deck - please phone 0800 449 272 or visit our website at www.BiForm.co.nz.

FORM 130 & FORM 140 Installation Guide

Facing Boards.

The same decking boards can be used vertically as a facing board. As with the surface decking, butt joints are not recommended.

It is best to install facing when boards have been in the sun and are expanded to its maximum. Surface fixing should be every 300mm to prevent bowing. When fixing through the surface predrilling is recommended.

Stop Clips.

Centre of Long Boards:

Stop clips are to be used in the centre joist of each board over 3.5m to balance the thermal movement at either end.

Either Side of Butt Joints:

Traditional hardwood decking is often installed using random butt joints. Due to the thermal movement that occurs in composite decking, butt joints are often not appropriate as the impact of this movement is effectively doubled. We strongly discourage the use of butt joints when using our decking.

However, if butt joining is appropriate because of excessive wastage, then we can offer a compromised solution through the use of 'Stop Clips'.

These clips help to stop the thermal movement at the ends of the boards, meaning alternate butt joints are a feasible option in certain situations.

See diagram below to understand how stop clips work:

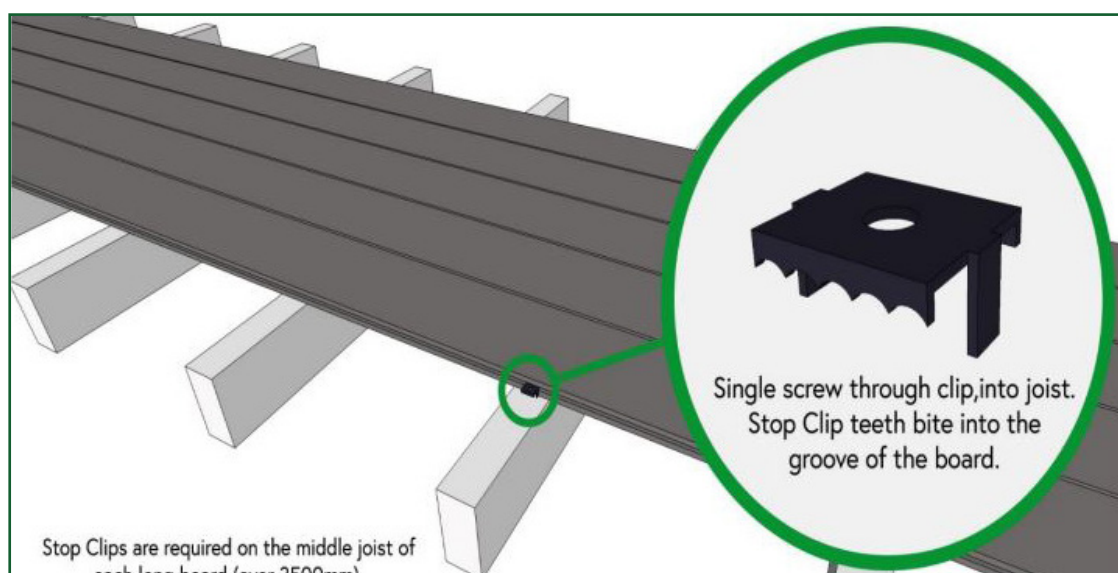

See diagram below, showing where to fix using stop clips:

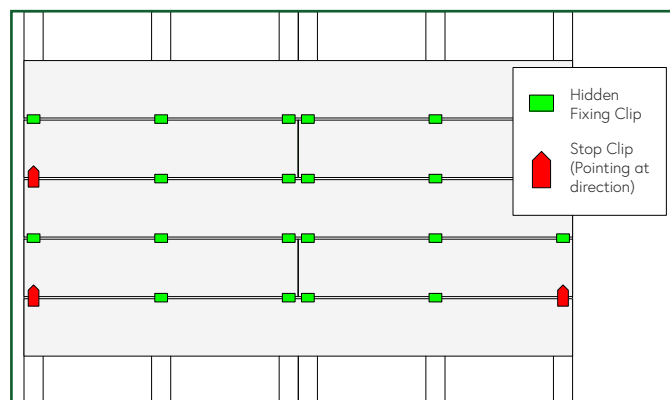

Only one stop is to be used per board, creating a maximum of one butt joint per run of decking.

Key Installation Points

- Use a picture frame design
- Use a breaker board at the ends of boards where necessary
- Avoid butt joints
- Joists at 400mm centres for FORM 130 Profile
- Joists at 450mm centres for FORM 140 Profile
- In windy exposures, use Windbreak Plus cloth - contact us for information on this custom solution.

FORM 130 & FORM 140 Installation Guide



Installation Guide.

Refer to this example of a typical 5m x 148m Form 130 deck (using timber substructure installed with reference to NZS 3604):



- Once you have installed your substructure with joists at 400mm centres, you are now ready to lay your boards.
- For help with substructure requirements please see our CAD drawings online at www.biform.co.nz
- Double joists are required for Boards A and M.

Step By Step Guide.

1. Cut your first perimeter Board A to size and lay. Surface fix a pair of screws at every joist with Torx Deck Screws 316 Stainless Steel. Do not cut Boards B-M to size at this stage.

2. Lay your second perimeter Board B. Make sure the end of the board is butted hard up against Board A.

Surface fix with Torx Deck Screws 316 Stainless Steel at every joist. Once this board is fixed into place, take your Fixing Clip & Screw and slide this into the edge groove of the board at every joist and screw into place.

Do not over-tighten these Black Screws as this can make the next board difficult to slide into place.

3. Lay Board C. Make sure that the end of the board is 2mm away from Board A. Slide this into place so that the Fixing Clip also slides into the edge groove of this board. You may need to use a rubber hammer to lightly tap the board into place, then tighten the Black Screw at every joist. Once again, do not over-tighten Black Screws. The Fixing Clip will hold these two boards down into place.

One "stop clip" per board over 3.5m to be used on a central joist to equalise thermal movement at each end of the board.

Once this board is fixed into place, take a Fixing Clip & Screw and slide this into the edge groove of the board at every joist and screw down, ready for your next board.

4. Repeat Step 3 until you have laid Board D-K, and allow 2mm gap.

5. Lay your third perimeter board, Board L, making sure that the end of the board is butted hard up against your first perimeter Board A. Tighten the Fixing Clip & Screw down, then surface fix this board with the Torx Deck Screws.

6. Now that you have laid your boards you are now ready to cut Boards B-L to size. Make sure your boards are all at a similar temperature.

7. Time to lay your last perimeter board, M, which can now be cut to size. Depending on the time of day, leave a 0 to 2mm gap from the ends of the newly cut board, B-L, and surface fix a pair of screws at every joist using Torx Deck Screws.

FORM 130 & FORM 140 Installation Guide



Installation Notes.

- Install perimeter board first. Surface fix it with Torx Deck screws. The board must be predrilled.
- In-fill with deck boards using concealed Black Fixing Clip & Black Screw on every joist and one stop clip per board on a central joist.
- Install the last perimeter/breaker board by surface fixing with Torx Deck screws, leaving the appropriate expansion gap.
- The decking expands and contracts lengthways due to the temperature changes throughout the day. BEFORE CUTTING, the temperature of each board should be assessed. Hot boards will shrink as they cool, and cool boards will expand as they heat up.
- Control of this longitudinal expansion can be achieved by laying the boards and then docking when they are all the same temperature. Use of a central stop clip can equalise the movement at both ends of the board. Install the perimeter board or breaker board at this time without leaving expansion gaps.

After Installation

Cleaning.

It is important to clean your deck immediately after installation.

A scrub with warm water and BiForm Deck Cleaner will help to speed up the weathering process of your BiForm deck.

Hose down with a garden hose. Use a sponge mop or a broom with the end wrapped in a towel to remove excess water.

Care & Maintenance.

Please forward the Care & Maintenance Guide, along with the Warranty, to the home owner/maintenance department.

Registration.

Please register your deck for warranty at our website:
<https://BiForm.co.nz/warranty-registration/>

Alternatively, scan the QR code to access the warranty registration page.



25 Year Limited Warranty



Product Covered:

Form 130, Form 140, Forest Face Fix 138

Warranty Cover:

For purchases made on or after 1st December 2015 - BiForm Ltd (hereinafter "BiForm") warrants to the original consumer purchaser (hereinafter "Purchaser" that, for a period of twenty-five (25) years from the date of original consumer purchase, under normal use and service conditions, BiForm's decking products (hereinafter the "Products"), shall be free from material defects in workmanship and materials, and shall not crack, split, splinter, rot or suffer structural damage.

This warranty does not cover costs of installation, removal or reinstallation including but not limited to labour and freight. This warranty does not cover staining, colour variations, fading or wind noise. BiForms sole responsibility shall be, at its option, to either refund the percentage of the original purchase price listed on the prorated Warranty Schedule or replace the defective product.

This warranty is subject to the Limitations and exclusions below.

Prorated Warranty Schedule:

Years Since Purchase:	Purchase Price Covered:
1-10 Years	100%
11-15 Years	75%
16-20 Years	50%
21-25 Years	15%

Limitations and Exclusions on the Warranty:

This 25 year Limited Warranty is void if any of the following occurs: (a) improper installation and/or failure to abide by BiForms installation guidelines; (b) movement, settling, distortion or collapse of the ground or supporting structure on which the BiForm products are installed; (c) naturally occurring casualties including impact of objects, earthquakes, tornados, hurricanes, lightning, flooding or acts of God; (d) improper handling or storage, neglect or misuse of the BiForm products either by the Purchaser, the transferee or third parties; (e) improper application of paint or other surface chemicals not recommended by the Manufacturer in writing; (f) adverse effects of air pollution and (g) normal weathering of surfaces (h) normal wear and tear.

BiForms liability with respect to defective products shall in no event exceed the replacement of the defective products or refund of the purchase price as described above.

This warranty may be transferred one (1) time, within a five (5) year period beginning from the date of original purchase by the Purchaser, to a subsequent buyer of the property upon which the BiForm products were originally installed.

BiForm shall not be liable for any incidental or consequential damages arising out of the use or ownership of this product. This Warranty gives you specific legal rights and you may also have other rights covered by consumer law.

25 Year Limited Warranty BiForm Decking



How to Claim:

To make a claim under this limited warranty, Purchaser, or the transferee, shall notify BiForm, in writing, within the warranty period referred to above, a description of the claimed defect and proof of purchase, to the following address:

BiForm Limited
P O Box 13842
Onehunga, Auckland, New Zealand

Warranty Registration



Warranty Registration QR Code:

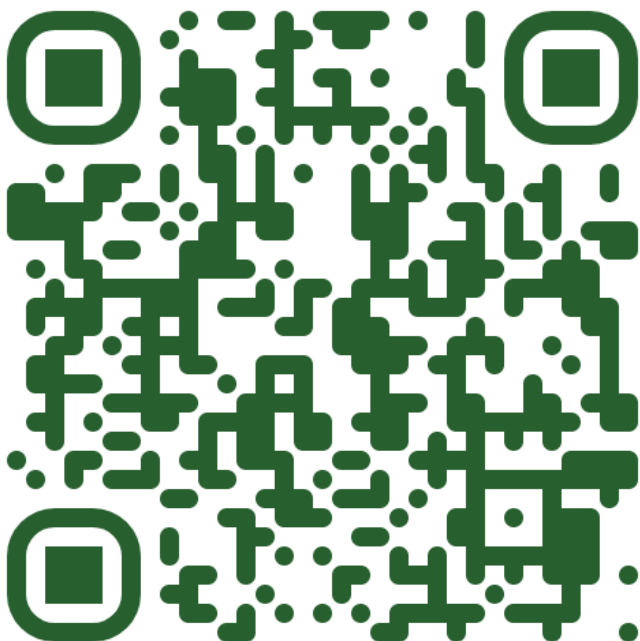

Warranty Registration:

We recommend that after installation, the final customer register their BiForm Decking product on our website.

Please register your deck for warranty at our website:
<https://BiForm.co.nz/warranty-registration/>

Alternatively, scan the QR code to access the product registration page.



Decking Care & Maintenance Guide

General Cleaning:

Keep it clean and your BiForm Deck with reward you with years of low maintenance pleasure. General cleaning with a broom or mop will suffice for most situations, however if you want to give a better clean, please use BiForm Deck Cleaner and scrubbing brush, at least annually.

Weathering:

Initially the deck will appear to be leaching and water staining. This is a weathering process which takes around 6 to 12 months to settle down depending on rainfall and the environment. To accelerate this process, scrub the deck down with BiForm Deck Cleaner, after the first summer the colour will have lightened up 10% to 20% and then will remain stable. Being a recycled product, colour variation of up to 8% from board to board can be expected.

Protecting:

We suggest a mat under your BBQ to protect from grease stains, and felt protectors under plastic or metal furniture to prevent scratching, gouging and potential rust stains. Avoid dragging heavy items over the deck as it will scratch. Scratches can be dealt with by giving a light sand, following the grain of the wood as described over.

Mould and Mildew:

If damp leaves are allowed to build up or the deck is in a shaded damp site mould or mildew may develop. This can be treated with 30 Seconds Outdoor Cleaner – new generation (blue label) following the manufacturer's instructions. For lighter colours situated in damp areas we suggest 6 monthly or annual spraying with 30 seconds Spray and Walk Away (green label) following the manufacturer's instructions. This will help prevent surface mould from forming.

Stains:

BiForm Decks, like wood, are susceptible to stains from BBQ grease, oil, and the tannin in some vegetation. Best results are achieved if the stain is treated immediately with absorbent cloths, then apply a degreaser as per the manufacturer's instructions. Follow up the degreaser with a general clean using BiForm Deck Cleaner or hot soapy water.

Scratches:

Scratches can be removed with a light sand using 60 grit sandpaper, following the length of the plank. The colour and texture changes which occur after this will recede with weathering.

Testing:

Test any treatment, cleaning products or sanding on a spare or obscured piece of decking to check for changes first.

Rinse and Dry:

After any cleaning, hose off and use an old towel wrapped around your deck scrub or a rubber scraper to remove the excess water. On a warm day the deck should dry with no water marks in a few moments.

Further Advice:

For further advice please contact us at:

- info@biform.co.nz
- 0800 449 274